

STORM WATER DETENTION

CONCRETE SEDIMENT BOX

STORM DRAIN WITH INTERNAL CATCH BASIN FOR HEAVY SOLIDS

INLET TO SAND AND OIL INTERCEPTOR COMPARTMENT

ENGINEERED DISCHARGE BY PUMP OR GRAVITY FLOW

NATURAL DRAINAGE SWALE

10 FT. DIA. 25,000 GALLON FIBERGLASS STORAGE TANKS AS REQUIRED

INLET TO SAND AND OIL INTERCEPTOR COMPARTMENT

CONCRETE SEDIMENT BOX

STORM DRAIN WITH INTERNAL CATCH BASIN FOR HEAVY SOLIDS

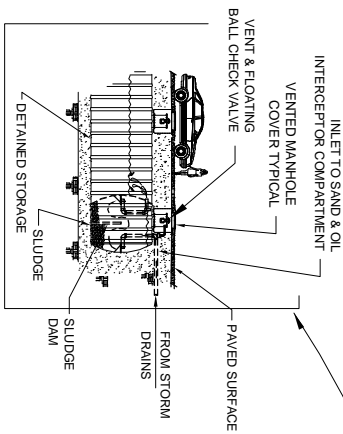

NOT TO SCALE, FOR ILLUSTRATION ONLY